

**UNIVERSITY COLLEGE TATI (UC TATI)****FINAL EXAMINATION QUESTION BOOKLET**

COURSE CODE	: BME 2063
COURSE	: JIGS AND FIXTURES
SEMESTER/SESSION	: 1-2022/2023
DURATION	: 3 HOURS

**Instructions:**

1. This booklet contains 5 questions. Answer **all** questions.
2. All answers should be written in answer booklet.
3. Write legibly and draw sketches wherever required.
4. If in doubt, raise your hands and ask the invigilator.

**DO NOT OPEN THIS BOOKLET UNTIL YOU ARE TOLD TO DO SO**

**THIS BOOKLET CONTAINS 5 PRINTED PAGES INCLUDING COVER PAGE**

**QUESTION 1**

- a) **Determine** three (3) aims when dealing with mass production. Provide the solution to fulfill those. (6 marks)
- b) **Identify** two (2) classification of jigs and fixtures. Provide one (1) example for each. (4 marks)
- c) **Distinguish** between a "Production device" and "Inspection device". (4 marks)
- d) **Explain** how to restrict the movement and positioned part properly. (4 marks)

**QUESTION 2**

- a) **Discover** three (3) basic rules for clamping and briefly explain. (6 marks)
- b) **State** four (4) methods of clamping are common to both jigs and fixtures. (4 marks)
- c) **Distinguish** between internal and external locators and how to positioning the locators. (7 marks)
- d) **Interpret** the term of nonmechanical clamping and the reason to apply this method. (5 marks)

## QUESTION 3

- a) **Classify** three (3) common types of drill bushings use in drill jigs. Choose any one (1) of your answer and explain in detail. (5 marks)
- b) **Illustrate** the three (3) installation methods for drill bushing and sketch. (5 marks)
- c) **Explain** the importance of specialized tooling for jigs and fixtures application in industries. (4 marks)

## QUESTION 4

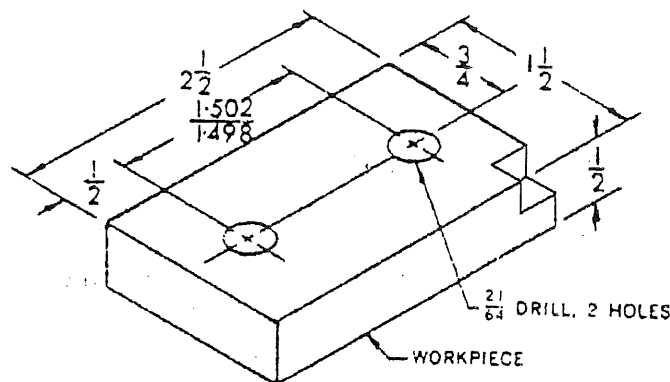

Figure – 1

- a) In the figure – 1 shown above is a workpiece called Block Support. Two holes needed to be drilled on one side of the support. In order to make sure correct and secured position is drilled, you need to design jigs and fixtures. **Sketch** a simple drill jigs design of maximum three views. (10 marks)  
(Note: No dimension needed in the sketch.)
- b) **Show** relevant supports and locators. Also add or **identify fool proofing element** to the sketch given. (10 marks)
- c) **Explain** the most efficient method of designing any jigs. (6 marks)

## QUESTION 5

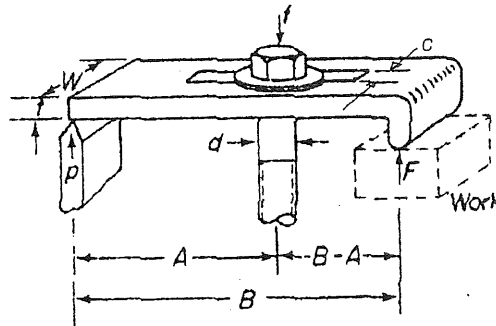

Figure - 2

From figure - 2 as shown above, assuming an **10 inch long** open-end wrench is used to tighten a  $\frac{1}{2}$  - **10 bolt** (Diameter of bolt  $d = \frac{1}{2}$ ). A force of **15 lb** is exerted at the end of the wrench.

**Calculate:**

- The necessary width of the clamp.
- The thickness of the clamp.
- The load on the bolt.
- The moment on the strap.
- The working stress on the clamp.
- The safety factor if the ultimate stress of the clamping material is **65,000psi**
- The maximum radial load that can be applied to this bolt.

Note:  $A = 3in$ ;  $B = 5in$ ;  $c = \frac{1}{2} + \frac{1}{16} = 0.5625$  (slot opening);

$$\text{Torque } (T) = 10 \times 15 = 150 \text{ in-lb.}$$

(20 marks)

$$[W = 2.3d + 0.062; t = \sqrt{(0.85dA(1-A/B))}; T = df/5; M = \frac{fA(B-A)}{B}; \text{sec.mod.} = \frac{(W-c)(t)^2}{6};$$

$$S = M/(\text{sec.mod.});$$

$$d = 1.35 \sqrt{(f/s)};$$

$$\text{Safety Factor} = S/Rm].$$

-----End of question-----

JIGS AND FIXTURES (BME 2063)

---

**RUBRIC**

Criteria	Marks
All questions answered will be marked according to the answer scheme	/ 100

